

Hollow Pin Stainless Steel chain 1



Features & Advantages



- Stainless steel material
- Moisture-proof
- Corrosion resistance
- Suitable for special occasions of strong acid/alkali, high/low temperature, humidity; etc
- Lubrication-free, clean on surface
- Suitable for occasions required of high degree of hygiene
- Used in applications with higher working loads
- Long service life

Technical Specifications

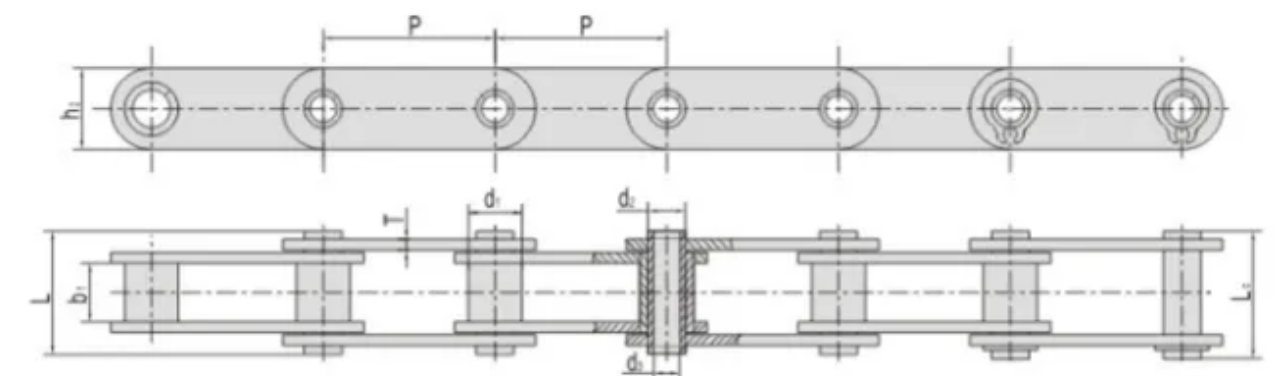

Email | sales@hdsusa.us

Tel | +1 (832) 808-5116 Tel | +1 (832) 808-5164



HDS Chain No.		08B HPSS	10B HPSS	12B HPSS	40 HPSS	50 HPSS	60 HPSS	80 HPSS
Bush Outer Diameter	P/mm	12.7	15.875	19.05	12.7	15.875	19.05	25.4
Width Between Inner	d1(Max)	8.51	10.16	12.07	7.92	10.16	11.91	15.88
Pin Diameter	b1(Min)	7.75	9.65	11.68	7.85	9.4	12.57	15.75
Plate Depth	h2(Max)	12.1	14.6	15.7	12	15	18	23.5
Pin Outer Diameter	d2(Max)	6.38	7.06	6.5	5.63	7.06	8.33	11.11
Pin Inner Diameter	d3(Min)	4.6	5.13	4.1	4	5.13	5.97	8.03
Pin Length	L (Max)	16.5	19.2	21.6	16.6	20.5	25.3	32.7
Pin Length	Lc (Max)	18	20.5	23.9	17.6	21.9	26.8	33.8
Ultimate Tensile Strength	Q(Min) KN	6	8.1	13.3	6.8	10.6	16.1	26.8